

RØDECASTER PRO II™

INTEGRATED AUDIO PRODUCTION STUDIO

The RØDEcaster Pro II is the ultimate audio solution for podcasters, streamers, musicians and content creators. It features four high-quality Neutrik® combo jacks for connecting both microphones and instruments, with ultra-low-noise, high-gain Revolution Preamps™ plus studio-grade APHEX® audio processing delivering superior sound quality. The nine channels – including six broadcast-quality physical faders and three virtual faders – are individually assignable for creating personalised mixer configurations to suit any recording setup. The eight fully programmable SMART pads can be used for everything from triggering sound and voice FX to activating mixer actions and sending MIDI commands. Advanced Bluetooth® connectivity, dual USB-C interfaces, and Wi-Fi and Ethernet connections offer unrivalled integration with computers, smartphones and other devices. The RØDEcaster Pro II is powered by a high-performance quad-core audio engine, which delivers peerless processing power. It is also incredibly simple to use, with a large high-definition touchscreen and rotary encoder for easy navigation, intuitive control over audio processing via VoxLab™, and professionally tailored presets.

- Ultra-low-noise, high-gain Revolution Preamps™ (-131.5dBV EIN, 76dB gain)
- Four high-quality Neutrik® combo inputs for connecting microphones and instruments
- Nine individually assignable channels with six broadcast-quality physical faders and three virtual faders
- High-performance quad-core audio engine
- Studio-grade APHEX® audio processing and on-board effects
- Eight fully programmable SMART pads with bank switching
- Dual USB-C interfaces and advanced Bluetooth® connectivity
- iMultitrack or stereo recording to a microSD™ card, USB storage device or computer
- Four high-quality headphone outputs and ¼-inch balanced line outputs
- 5.5-inch high-definition touchscreen with haptic feedback and rotary encoder for easy navigation and control
- Seamless multi-location connectivity between RØDEcaster Pro II and RØDEcaster Duo devices, or via web-browser, with our integrated RØDE CallMe feature

●
Black



○
White



REVOLUTION
PREAMPS™



MIC, LINE &
INSTRUMENT INPUTS



STUDIO-GRADE
PROCESSING



SMART PADS



ADVANCED
CONNECTIVITY

rode.com



ACOUSTIC & ELECTRICAL SPECIFICATIONS

Frequency Range:	Mic Inputs: 20Hz – 20kHz Monitor Outputs: 20Hz – 20kHz
Microphone Input Impedance:	4KΩ
Instrument Input Impedance:	1MΩ
Input Dynamic Range:	113dB
Preamplifier Gain Range:	0 – 76dB
Equivalent Noise:	-131.5dBV (A-weighted)
Line Output Maximum Level:	4dBu
Headphone Output Power:	250mW
Power Requirements:	30W USB-C PD (15V, 2A)
Analogue Audio Input Connectivity:	4 x combo jack inputs (microphone, line, instrument)
Analogue Audio Output Connectivity:	2 x balanced line output, 4 x headphone output
Bluetooth Connectivity:	Bluetooth audio with Music and Headset profile (wide band speech)
USB Interface 1:	1 x 2-in/16-out multichannel device, 1 x 2-in/2-out with mix-minus
USB Interface 2:	1 x 2-in/2-out with mix-minus

RØDE

ACOUSTIC & ELECTRICAL SPECIFICATIONS

Bit Depth:	24-bit
Sample Rate:	48kHz
Recording Storage:	microSDHC, microSDXC, USB-C removable drive (exFAT – minimum 100MB/s)
Data transfer:	USB 3.0 SD card reader 130MB/s
Network connectivity:	WiFi 802.11g/n/ac 2.4GHz and 5GHz, Ethernet 100/100 (WPA2 or WPA2-Personal network types)
OS Requirements:	Mac OS 10.15 or later, Windows 10 Version 1803 or later, Windows 11
Internal Storage:	4GB (SMART Pads)

MECHANICAL SPECIFICATIONS

Weight (grams):	1960
Dimensions (millimetres):	Length: 305 Width: 270 Height: 60
Included Accessories:	1 x RØDECaster Pro II 1 x Power Adaptor 1 x SC27 USB-C Cable

WHAT'S IN THE BOX



RØDECaster Pro II



Power Adaptor



SC27

DIMENSIONS

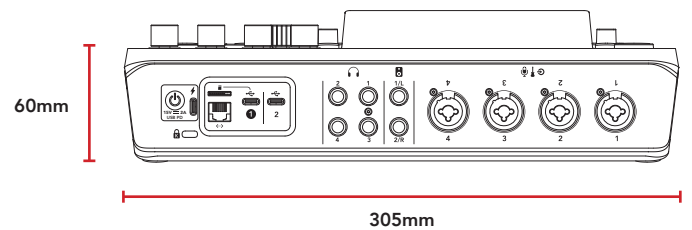
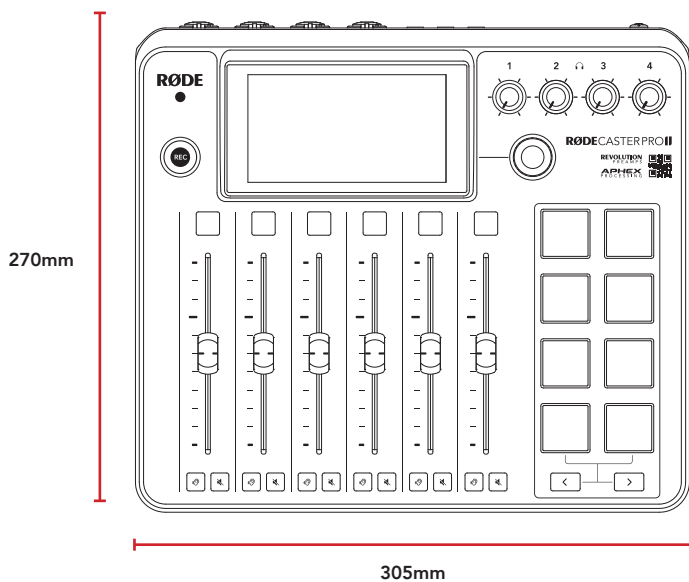

PODMIC

DYNAMIC PODCASTING MICROPHONE

The PodMic is a broadcast-quality dynamic microphone optimised for incredible performance in podcasting, livestreaming, and other speech or vocal applications. Offering a rich, full-bodied sound, with an internal pop filter for minimising plosives, internal shockmount for reducing vibrations, and a swing mount for easy positioning, the PodMic will take your content to the next level.

- Broadcast quality dynamic capsule
- Optimised for speech applications
- Internal pop filter to minimise plosives
- Robust, all metal construction
- Optimised for use with RØDECaster Pro consoles



BROADCAST
QUALITY



INTERNAL
POP FILTER



RUGGED BUILD



2 YEAR
WARRANTY



SPECIFICATIONS

Acoustic Principle:	Dynamic
Polar Pattern:	Cardioid
Frequency Range:	50Hz - 15kHz
Output Impedance:	320Ω
Sensitivity:	-57dBV (1.4mV @ 94dB SPL) +/- 2dB @1kHz
Output Connection:	XLR
Phantom Power:	Not required
Colour:	Black and White
Weight (grams):	937
Product Dimensions (millimetres):	Length: 172 Width: 109 Height: 62
Compatible RØDE Accessories:	PSA1+ DS1 DS2
Features list:	Integrated swing arm



Black



White

WHATS IN THE BOX



PodMic
(Black or White)

DIMENSIONS

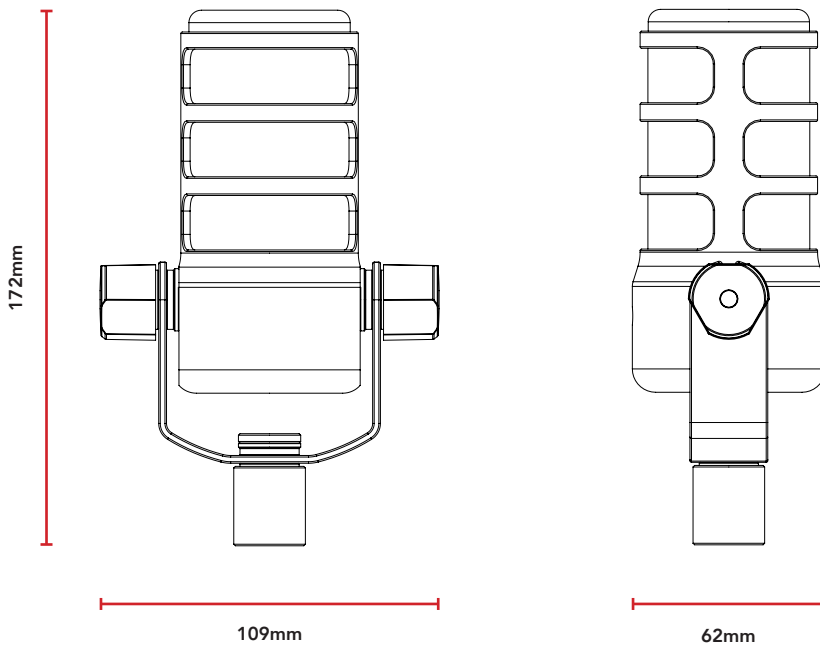

POLAR PATTERN

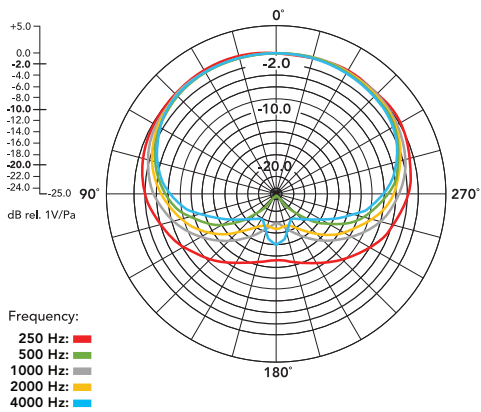

FREQUENCY RESPONSE

